

# Touch keypad Wi-Fi/GSM Alarm System User Manual

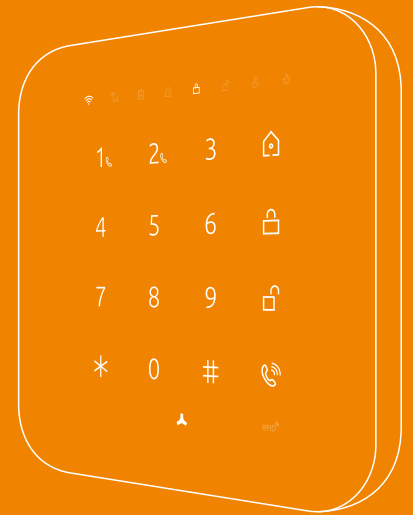

## Content

- 01 Product list
- 02 Features/Control Panel Appearance
- 03 Working Status of Control Panel Appearance

### Quick Start Guide

- 08 Installation of The Control Panel

### Included Accessories

- 11 PIR Motion Detector
- 14 Door/Window Sensor

### Setup

- 16 Mobile App Setup
- 16 Add Device
- 18 Electrical Facility Control
- 19 Alarm Notification
- 20 Accessories Enrollment/Delete
- 22 Zone Setup via App
- 23 Device Setup

### Mobile App

- 27 Other APP Settings
- 30 Connecting Wired Accessories & Linkage Electronic Facilities

- 31 SMS Text Operation

- 32 Specification

- 35 Q & A

The dual network security system is built to offer convenient, real-time monitoring and flawless home security. It protects your home 7/24. The control panel is the brain of security alarm system, which is able to communicate with all wireless sensors. If an intrusion is detected or if an abnormal amount of smoke is detected, it triggers an immediate alarm and send you notification by SMS, push notification and calls.

## Product List

Please remove all supplied contents from packaging as below. If there' re anything missing, please return to your place of purchase.



Control Panel



Door/Window Sensor



P.I.R. Motion Detector



Remote Control



RFID Card



Wall-mounted Bracket



Bracket for Motion Detector



3M Double-sided Tape



Batteries



Plastic Plugs & Screws



User Manual



Power Adapter



## Features



Totally Wireless,  
DIY Installation



108dB Siren



24 Hours Protection



Entry/Exit Delay



Wi-Fi + GSM,  
Double Safety



FHSS Frequency-Hopping  
Spread Spectrum



Immediate  
SMS Alerts



3 Groups of SMS  
5 Groups of Phone Call  
2 Groups of Central  
Monitoring Station



6 Hours  
Battery Back-up



10 Customizable  
Keyfob Name



Added on up to  
50pcs Sensors



Door Sensor  
Monitoring



50 Zone Names



iOS & Android App,  
Easy to Setup



## Working Status of Control Panel

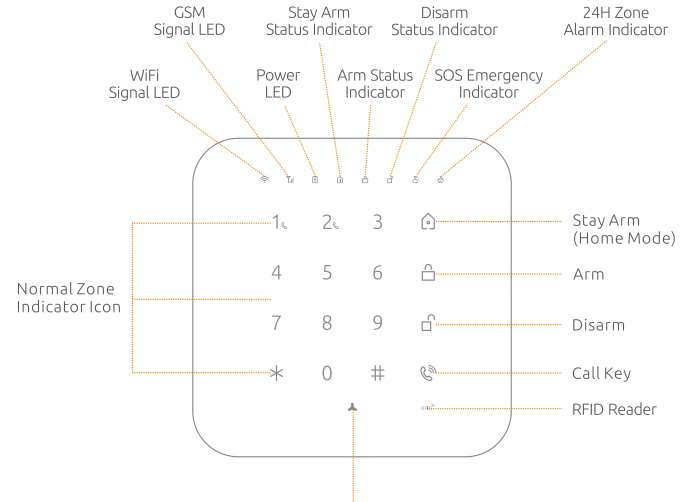

### Wake up Key

Press "▲" icon to wake up the touch keypad

### Zone Alarm Indicator

LED comes on when normal zone sensors are triggered.

### Escape Key

## How to Use the Alarm Touch Keypad

### Wake up Key

You are able to wake up the alarm system from sleeping mode by pressing the "⏏" once.

**Note!** No operation on the keypad over 20S, the background light will be off.

### Make a call

Wake up the touch keypad, type in the phone number, and then press the Call Key "☎" to start the call.

### Speed Dialing

The system allows you to program up to 2 frequently called phone numbers reduced to a single digit (1 or 2).

#### To store speed dial numbers:

Open the app, enter Alarm System Dashboard > Setting > Store Alarm Phone Number > Speed Dial Numbers > Enter the numbers to store > Save

#### To dial speed dial numbers:

Wake up the touch keypad, then press and hold the number 1 or 2, the number will be dialed immediately.

**Note:** If you enter the wrong numbers, tap the wake up key "⏏" to erase the numbers and call again.

## 4 Ways to Control the Alarm System

### Arm

Arm the system when leaving your home. All sensors will be activated. Any sensors that are triggered will immediately sound the alarm.

### Disarm

Disarm the system when entering your home. All sensors will be deactivated allowing you to move freely.

### Two-way Talk

Listen into the room via the control panel and also speak with people in the room.

### Home Mode

Sensors that are designated in the Home Zone are deactivated, allowing you to move freely in your home. The sensors in Normal Zone will remain active and if triggered, will immediately sound the alarm.

### Mute Mode

Press stay arm button, then press arm or disarm button within 3 seconds to enter into arming or disarming state in mute mode without disturbing someone.

### Emergency Call

Press the SOS button in the event of an emergency. This will trigger an immediate alarm even if the system is disarmed or in Home Mode.

To stop the alarm, press the disarm button on the app or remote control.

#### You can arm, disarm and switch between security modes using:

- 1.Touch keypad on alarm control panel
- 2.RFID Cards
- 3.Smart Life Apps
- 4.Remote Control

#### Using Touch Keypad



#### Using RFID Cards





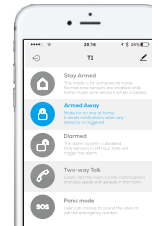

#### Tap on device "T1", enter the device interface.



#### Through the Remote Control (Press and hold the buttons for about 1 sec.)

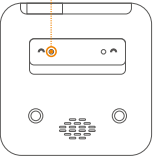

No	Name	Function
1	 GSM Signal Status LED Indication	<b>Flashes quickly:</b> No SIM card or no signal <b>Flashes normally:</b> GSM network found
2	 Wi-Fi Status LED Indication	<b>On:</b> Wi-Fi network connected. <b>Off:</b> Wi-Fi network lost. <b>Flashes quickly:</b> Start setup with the app in smart configuration. <b>Flashes slowly:</b> Start setup with the app in AP configuration.
3	 Power LED Indication	<b>On:</b> Power on <b>Off:</b> Power off <b>Flashes:</b> System in low battery
4	<p><b>Button</b> Tamper Switch</p> 	<p><b>Tamper Switch</b> Press Once: Trigger tamper alarm</p>
5	 Touch Keypad	<p><b>Touch Keypad</b>            Password*0# : Delete all the enrolled accessories.            Password*1# : Start enrollment with the new accessories.            Press*and hold for 5 seconds : Start setup with the app.            Password*3# : Reset the system to factory setting.</p>

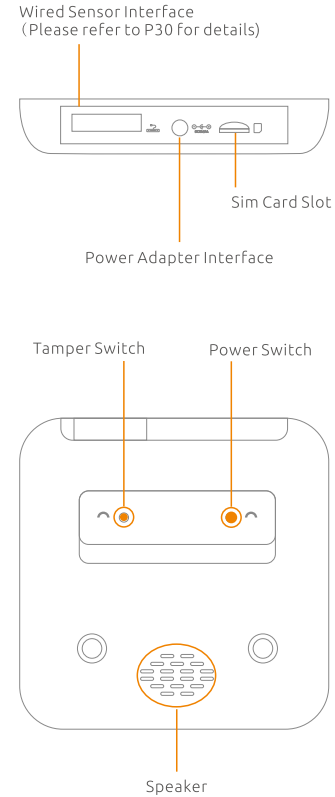

# Quick Start Guide

## 1. Installation of The Control Panel

- A. Insert a SIM card and fix it.
- B. Insert power adapter's barrel plug to adapter socket.
- C. Press the switch button.
- D. Test the enrollment of accessories.

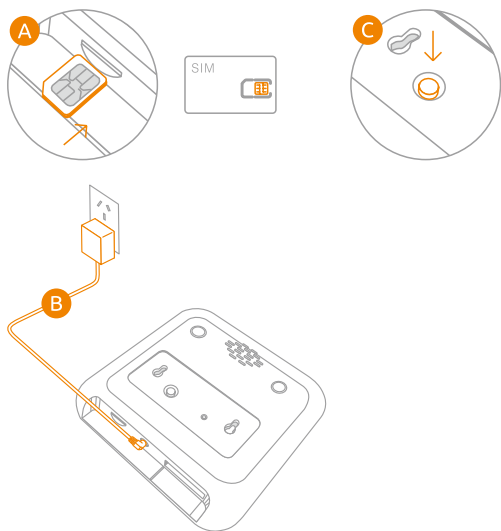

### Important:

The sim card you have purchased may not ask for a PIN. However should your SIM card requested a PIN, you can switch off the PIN request by briefly using the SIM card in a mobile phone.

After testing, screw the mounting bracket to the wall, connect the panel to the bracket.

## 2. Using and Testing the Remote Control(s)



- A. Press the panic button " SOS ". A small display on the remote control will briefly light up. A loud alarm tone will immediately sound and the symbol on the control panel will flash red .
- B. Turn the alarm off again by pressing the disarm " " button. Congratulations! Your remote control( s ) are working!

## 3. Using and Testing the Door Sensor



- A. Pull out insulating strip.



- B. Arm the system with " " button.



- C. Now separate both parts of the sensor and hold them at least 2cm away from one another. A red light will briefly flash on the sensor



- D. As soon as the alarm sounds, disarm the control panel with " " on the remote control. Congratulations. The door sensor is now working!

## 4. Using and Testing the Motion Detector



A. Carefully open the cover of the motion sensor by pressing the clip and pull out insulating strip.



B. Fix the cover by the short screw.



C. Arm the system with "  " button.



D. Now press the small, black button (program) on the rear of the motion sensor.



E. As soon as the alarm sounds, disarm the control panel with "  " on the remote control. Congratulations.  
The motion sensor is now working!



F. Using RFID Cards  
You can disarm the security system by placing it close to the "RFID" area on the touch keypad. The RFID Cards can be featured of arming, disarming or both which can be selected on



## Wireless P.I.R Motion Detector

### Features

The passive infrared sensor with novel and beautiful style, perfect streamline can be easily installed. It is designed to detect human movement indoor. Adopted advanced fuzzy logic chip and intelligent analysis distinguish signal between body movement and interference to minimize false alarms. The built-in buzzer remind you low battery state and event of tamper alarm, which ensure your safety.

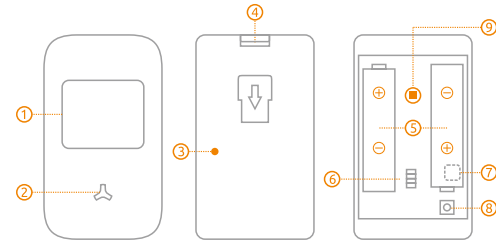

1. Detection Window
2. LED Indicator
3. Learning Button
4. Clip
5. Battery Compartment

6. Zone Jumper
7. Buzzer
8. Tamper Switch
9. Infrared Sensor

**Infrared Sensor:** Detects the infrared rays released by human body motion. Please do not touch the surface and keep it clean.  
**Tamper Switch:** Once the case is opened , the tamper switch will be triggered, generating an alarm signal.

## Status Indicator



### LED Flashed Once:

Movement is detected, Tamper alarm.

### LED Flashes Once each 3 seconds:

Low battery indication.

If it's in low battery state, please replace it immediately.

## Test Mode & Normal Operation

With the Detector powered on, the light should turn on immediately and will keep flashing while the sensor warms up, for approximately 15 seconds. It will then turn off.

**Test Mode:** After warm-up, walk through the coverage area and the light should turn on. This confirms that the movement is detected. The detector will recognize the movement 5 times. The interval time between each detection should be more than 2 seconds. Then it enters in sleeping mode.

**Sleeping Mode:** The detector will go to "sleep mode" for 3 minutes. It will sense motion or movement twice after "sleep mode". The mode helps save considerable amounts of energy when the house or apartment is inhabited and people are constantly moving around. In case of an alarm, however, the two detection is enough to trigger an alarm.

### Walk Test:

After the sensor warm up, walk across detection area and watch the LED indicator to make sure it flashes once when detecting the movement.



## Notice

1. Avoid mounting the detector close to places where heat changes fast or air stream flows frequently. (ie. Air conditioner, tube light, oven, waver, refrigerator etc.)
2. Avoid it facing to window which can be easily interfered by complicated environment. (ie. sunlight, crowds, or flowing cars etc.)
3. The product can reduce the possibility of accident, but the user is advised to take all necessary precautions for the safety and the protection of the property.

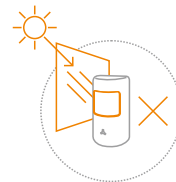

## Detection Area

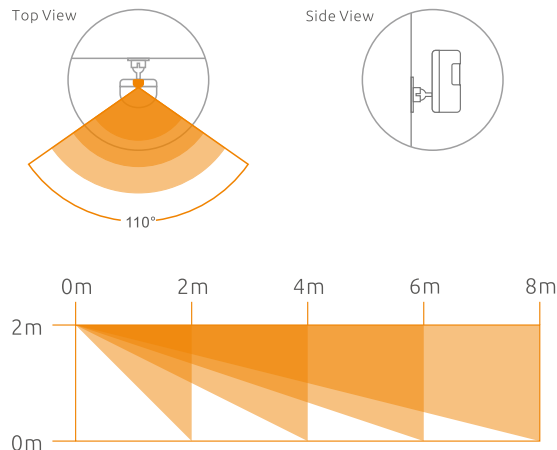





## Wireless Door/Window sensor

The Door/Window Sensor can be installed on doors, windows and any other objects that open and close.

The sensor transmits signal to control panel when the magnet mounted near the sensor is moved away.

The tamper protection ensures that sabotage attempts to move the sensor will result in an alarm activation.

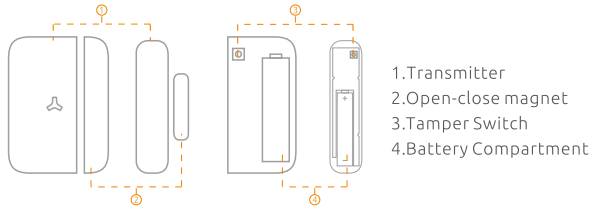
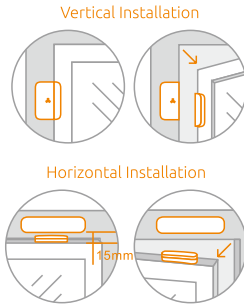

**Tamper Alarm:** Once intruder attempts to move the sensor, built-in buzzer beeps. The control panel will send tamper alarm message to user at the first time.

## Working Status:



### LED flashes once:

Door or window is opened.  
and the transmitter sends signal to the control panel.

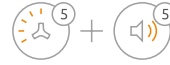

### LED flashes 5 times, and buzzer beeps 5 times:

Tamper alarm, low battery indication. If it's in low battery state, please replace it only with 1.5V/AA LR6 Manganese Dioxide Cell (EXCELL, GP) immediately.

## Installation:

1. Open the case and install the battery properly.
2. Sensor can be installed on door or window that open and close. Make sure the installed position have been already cleaned.
3. Remove the paper strip of the double-sided tape on the back of transmitter and magnet. Carefully mount the transmitter on the door frame and the magnet on the door.
4. Keep LED Indication light  at the right direction. Make sure the magnet is on the right of the transmitter.
5. Place the transmitter in the desired location, mount the magnet no more than 1cm away from the transmitter.
6. Avoid mounting sensors in areas with a large quantity of metal and electric wiring.

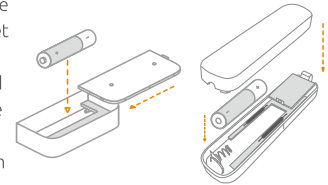
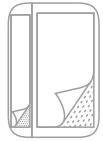

**Note!** The door sensor is set in Normal Zone1 as default. It will cause an immediate alarm if the magnet depart from the transmitter more than 2cm in arming state.

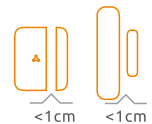

## Mobile App Download

Please enter keyword **"Smart Life"** on your smart phone to download the App from the Apps store or Google Play.



Smart Life

Wi-Fi Network: 2.4GHz (802.11 b/g/n).

iOS Requirements: iPhone 4S or newer running iOS 8 or higher.

ANDROID Requirements: Android 4.0 or newer.

## Create an Account

Tap on **"Register"** and follow these steps to create an account for your devices.

## Add Device

1. Tap on **"Add Device"** or **"+"**. Tap on **"Security & Sensor"** and choose **"Alarm System(Wi-Fi)"**

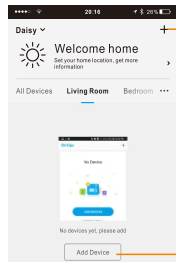

Add device



Alarm  
(Wi-Fi)

2. Select 2.4G Wi-Fi network and enter your Wi-Fi password.

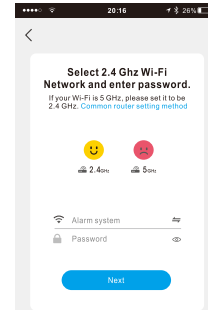

3. Turn on the device and confirm that **Wi-Fi Status LED** "Wi-Fi" of the device flash in red quickly.

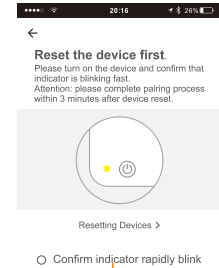

How to make Wi-Fi Status LED "Wi-Fi" flash in red quickly?

\* Turn on the device, then press the **enroll/reset** button for 5 seconds

4. Waiting for seconds while connecting.

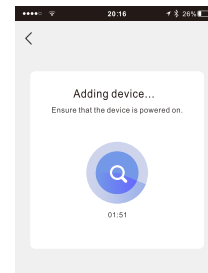

5. Device added successfully. Then you can rename the device and choose where you place the device.

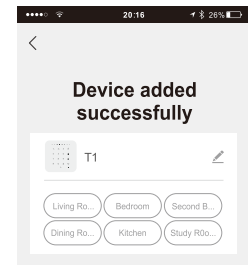



## Electrical Facility Control

Tap on “” to turn on electronic facilities like lights, or fences to deter the intruder immediately in the event of alarm.

**Note!** Electrical Facility is Off as default. To activate electrical facility, AC power of control panel must be on.

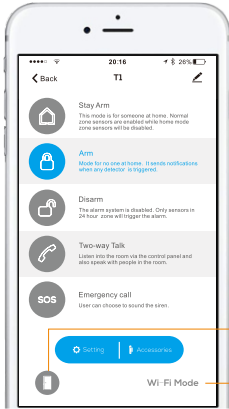

Electrical Facility Control  
Check the connecting method on page 30

Check Event Log

## Alarm Event/Notification

The alarm system monitors your home for activity and sends you an app push notification, calling or SMS when sensors are triggered. All events can be checked by tapping on “Me-Message Center” . The notification rule is as below. If “Setting-Push Notification” is disabled, then you will not receive app notifications when events are detected but still have calling alert and email notification.

## Alarm Notification

	Push Notification	SMS	Call	Mark
Smart Alarm WiFi ON	✓	✗	✓	Call phone number 1,2,3,4,5 If anyone pick up the phone, then it will stop calling next. If anyone disarm by clicking on button from notification window, then the call ends too.
Smart Alarm WiFi OFF	✗	✓	✓	Call phone number 1,2,3,4,5 If anyone pick up the phone, then it will stop calling next.



## Phone Remote Control

In the event the alarm, the alarm system will call the preset phone number, user can pick up the phone , monitor the site, and remotely control system by entering below numbers.

- Disarm the system, press 0;
- Arm the system in the away mode, press 1;
- Turn on AC facility, press 5;
- Turn off AC facility, press 6;
- Turn on on site siren, press 7;
- Turn off on site siren, press 8;
- Monitor the site, press \* key;
- Press escape (#) or hang up to exit.





## Accessories Management

Tap on "  "icon the into accessories menu, you can customise the accessory name, select the zone type, and also delete the accessory from the app, if required.

### Accessories Enrollment & Zone

You are able to pair up to 50 additional sensors, 50pcs RFID cards, 10 remote controls or keypads to the alarm system. Sensors that are included with the alarm system are already enrolled with the control panel. More accessories can be paired in two ways.

Press the enroll button .

**Step 1**, Press the enroll code on touch pad or select the "  " on the dashboard to enter the Accessories menu, then tap on "  " icon.



Input "XXXX\*1#" ( XXXX is password, the default password is 1234)

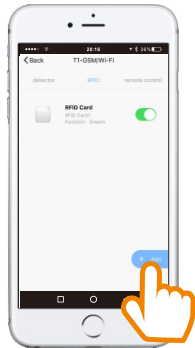

**Step 2**, Trigger the sensors one by one, press the enroll button again or press "  " icon on the app to exit the enrolling . The enrolled sensors will automatically appear in the Accessories menu in the app.

How to trigger different accessories:



Press any button on the remote control.

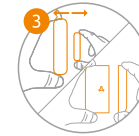

Move the transmitter away from the magnet



Press the black button on the rear of the motion sensor.

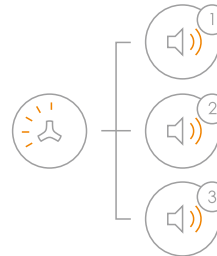
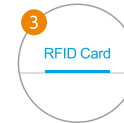
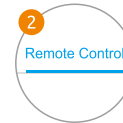
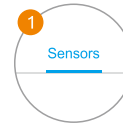

1 System beeps once, the LED light flashes once, the enrollment is successful.

2 If system beeps twice and the LED light flashes once, the accessories have been enrolled before.

3 If three beeps are heard and LED light flashes once, the storage is full.

(Note! Please don't press tamper switch to enroll or enroll accessory in low battery status, it will remain in enrolling mode for 30 seconds. )

### Delete Enrolled Wireless Accessories

Delete accessories via APP or Press "Password\*0#" on touch keypad until one beep is heard, all enrolled wireless accessories will be deleted.

## Zone Setup

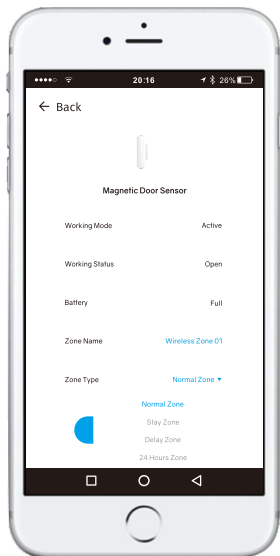

 :Full power,  :Low Battery



### Normal Zone

The alarm is activated immediately when triggered.



### Delay Zone

It allows a delay before entry or exit especially for sensors in single delay zone. But accessories in normal zone, home mode zone, and 24H zone will not be delayed.



### Stay Zone

Press "  " button, sensors in home mode zone are disabled then the users can move freely. While the sensors in normal zone will still activate an immediate alarm when triggered.



### 24 Hour Zone

No matter what state the alarm system is in, the accessories in 24 Hour zone are triggered, the control panel will get the signal and alarm immediately.



## Device Setup

Tap on "  Setting ", enter the setting interface.



### Google Home Security Code

Use the security code to disarm the alarm system via Google Home. Voice Control for Google Home : Disarm "device name". Set "device name" to home mode Set "device name" to away mode



### Siren Duration Time

User can set the siren duration from 0s to 300s, the device will be in mute when user set it 0s.



### Store Alarm Phone Numbers

Add phone numbers you want to control over. These numbers consist of three SMS numbers (receiving security messages and alerts), five Tel numbers (receiving alarm calls), and two CMS numbers. It's recommended to set the numbers according to the priority.



### Schedule

Schedule the arming and disarming of your security systems at your convenience. Time tolerance may be about +/- 30 seconds.

### Central Monitoring Station Setup



#### 1. Change User ID (Programm User ID for Central Monitoring Station)

The user ID is the Central Station Account number, which should be 4 digits between 0 and 9.



## 2. Report Upload

Report upload function is disabled as default. If the user needs to connect the central monitoring station, report upload function should be enabled. If enabled, notifies the central station by sending alarm report if alarm event occurs from the security system..



## 3. Store CMS Phone Numbers

User can set 2 CMS Phone Numbers on menu of " Store Phone Numbers"

## Contact ID Event Code and Content

Event Code	Event Content
3401	Arm
1401	Disarm
1132	PIR Motion Sensor Alarm
1131	Window/Door Sensor Alarm
1100	Emergency call
3456	Stay Arm
1137	Control Panel Tamper Alarm
1144	Detector Tamper Alarm
1140	Normal Alarm
1133	24H Alarm
1384	Detector Low Battery
1302	Control Panel Low Battery
1301	Control Panel AC Power Lost



## Exit/ Entry Delay

Set exit/entry delay time for accessories in single delay zone. It allows users to leave or enter home within the programmed time without activating an instant alarm. Once entry/exit delay time is set, when system is armed, in case of delay time less than 10 seconds, control panel will beep once every second. While delay time more than 10 seconds, control panel will beep once every 2 seconds, the sound will increase in tempo for the last 10 seconds for the "hurry up" notification. Once an entry is detected, it will allow the user to enter and disarm the system within the programmed entry time.



## Alarm Type

User can set the siren to be audible or silent when it's alarming.



## Wired Sensor Type

Choose the types of wired sensors after they are connected, N.C. or NO.



## Keyfob Arming/Disarming Alert

When the system alarms, users can choose whether to get push notifications and SMS alerts if someone operates it via keyfob.



## Device Language

Change system language as you want.



## Door Sensor Monitoring

If you leave a door or window open when you arm the system, the alarm will send a alert notification. User can check the real-time status of which sensor is "open" on the sensors list.



### GSM Signal Monitor

When the GSM signal is lost, the system will raise an alarm. When GSM signal is lower than 20, the system will send SMS notification.



### Turn on/off Local Siren

When you turn on the local siren, the control panel will alarm immediately.



### Sim Card Balance

Check your balance by sending a text of balance checking code that says “\*\*” to carrier service number.



### SMS Access Code

Setup-->Change Access Code-->Reset Password, user can change the password, the default password is 1234. The password should be 4 digits between 0 and 9. The password is used for operating by SMS when Wi-Fi network is off.



### Phone Number of Alarm System

Add phone number of the one you insert in the alarm system.



## Other APP Settings

### My home

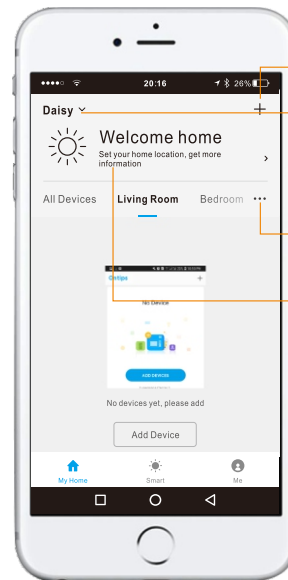

- Add devices
- Home Management  
Family settings: Name change/  
Room management/Family  
location/ Share advices  
Add Family/Add rooms.
- Room Management  
Add/Delete/Edit rooms
- Set Home Location

## Smart

Tap on "Smart" to add smart scene or automation of your connected devices.

For example, arm the system, and turn off the smart bulb.  
Or disarm the system, and then turn on the smart bulb.  
Or to execute the actions according to different conditions. For example, when temperature greater than 40°C, trigger the alarm system.

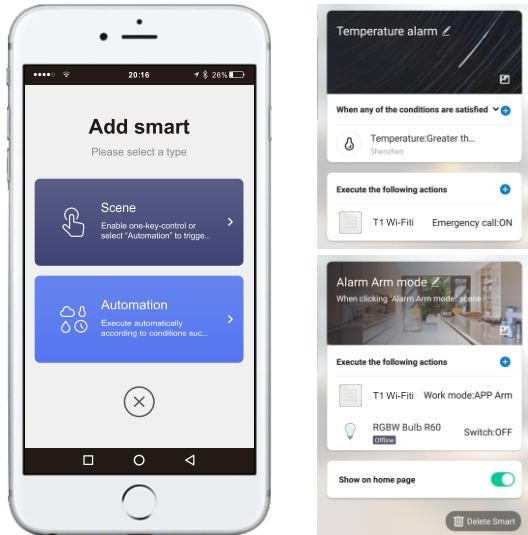

## Me

1. Check the activities of the system

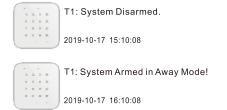

2. Add other services, like Alexa...



3. Write down and send us your issues or complaints or any feedback.

4. Sound: Turn on/off the sound of the key on APP.  
Notification: Receive the push notification or not.

Sound



Push Notification

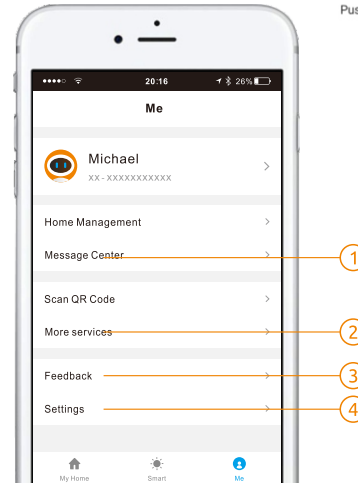





## Connecting Wired Accessories & Linkage Electronic Facilities

### Connecting Wired Accessories

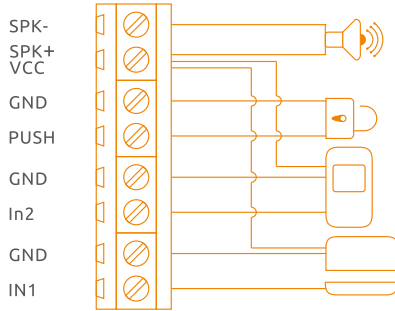

1. Connect one wire to IN1 or IN2 block while another to GND block. If no power supply is needed for wired sensor, don't connect to VCC block.
2. Connecting Wired Siren or facilities like lights. Connect THE Positive pole to SPK+ while the Negative pole to SPK-.  
Note: The output of facilities should not more than 500 mA.
3. Connect PUSH and GND of electronic lock.

**!** Note: Wired Zone 1 is 24H Zone. No matter the system is armed or disarmed, the control panel will get the signal and alarm immediately once it is triggered. Wired Zone 2 is Normal Zone. Once triggered in arm state, the system will receive signal and activate the alarm immediately.



## SMS Text Operation

If the Wi-Fi internet ever drops out, the GSM unit will quickly take over and send signals out. It's recommended to use mobile apps to control the system even when the system works in GSM mode. And it's easy for users to manage functionality through your cell phone by sending SMS text commands listed as below.

Function	SMS Text Operation		
	Send this operation code from your cell phone	SMS reply you will receive	Remark
Disarm	1234#0	System Disarmed	---
Arm	1234#1	System Armed in Away Mode	---
Stay Arm	1234#2	System Armed in Stay Mode	The Arm/Stay function will arm the system with sensors in normal zone activated immediately, but sensors in home mode zone disabled.
SOS Button	1234#SOS	Emergency Call !	Trigger the immediate alarm !
Electrical Facility	1234#91	Electrical Facility on	To activate electrical facility, AC power of control panel must be on.
Two-way Talk	43	---	Send "43" to the SIM card number, the control panel will call back. You can now listen in and have a two-way talk.



## Specifications

Product Name :	Wi-Fi/GSM Alarm System
Control Panel's Power Supply :	Input: AC 110~240V/50~60Hz Output: DC 12V/1000mA
GSM Working Frequency :	2G: GSM 850/900/1800/1900; 3G: WCDMA 850/900/1900/2100 for option
Standby Current :	200 mA without power supply. 150 mA when power supply on.
Alarm Maximum Current	≥350mA
Internal Battery Backup :	Lithium Battery: 3.7V/900mAh
Internal siren :	108dB
Allowed Amount of Expandable Wireless Accessories	10pcs remote controls 50pcs wireless accessories 50pcs RFID cards
Operating Frequency:	2.400~2.4835GHz
Wi-Fi Standards:	802.11b/g/n
Radio Frequency	FHSS 433MHz
Housing Material	ABS plastic
Operation Condition:	Temperature: -20°C~55°C Humidity: ≤ 80%(non-condensing)
Size (L x W x H) :	135×135×25mm
Bracket Size (L x W x H) :	83.5×27×3mm



## Specifications

Power Supply:	DC1.5V (AA 1.5V Lr6 Battery x1)(EXCELL, GP)
Standby Current:	≤25 μA
Transmit Current:	≤70mA
Wireless Transmit Distance:	≤100m (in open area)
Wireless RF Frequency:	FHSS 433MHz
Temperature/Humidity:	-10°C-55°C/≤80% (Non-condensing)
Detector Dimensions(L x W x H):	24.5 x 96.5 x 19.5 mm
Magnet Dimensions (L x W x H):	14 x 48 x 11 mm



## Specifications

Power Supply:	DC1.5V (AA 1.5V Lr6 Battery x1)(EXCELL, GP)
Standby Current:	≤20 μA
Transmit Current:	≤70mA
Wireless Transmit Distance:	≤80m (in Open Area)
Wireless RF Frequency:	FHSS 433MHz
Temperature/Humidity:	-10°C-55°C/≤80% (Non-condensing)
Dimensions (L x W x H):	48 x 71 x 18mm



## Specifications:

Power Supply:	DC 3V (AA 1.5V LR6 Battery x 2pcs)(EXCELL, GP)
Standby Current:	≤20 μA
Transmit Current:	≤30mA
Detection Area:	7-8m/110°
Wireless Transmit Distance:	≤80m (in open area)
Wireless RF Frequency:	FHSS 433MHz
Temperature/Humidity:	-10°C-55°C/≤80% (non-condensing)
Detector Dimensions (LxWxH):	90x 52x 36.5mm
Bracket Dimensions (LxWxH):	48x 26x 29mm



## Specifications:

Power Supply:	DC 3V (CR2032 button cell batteries x 2pcs)
Transmit Current:	≤25mA
Wireless Transmit Distance:	≤80m (in open area)
Transmitting Frequency:	FHSS 433MHz
Housing Material:	ABS plastic
Working Temperature:	-10°C-55°C
Humidity:	Up to 80% (non-condensing)
Dimension(L/W/H):	37x70x11.5mm



## Frequently Asked Questions

### 1. Is it possible to expand more accessories for this security system?

Yes, 50pcs sensors and 10 remote controls can be expanded according to users' need. Full range of accessories will be offered including PIR motion sensors, door sensors, vibration sensors, flood sensors, keypads, sirens, premiere protection beams & fences, and environmental sensors like smoke sensors.

### 2. What happens in case of alarm?

Wi-Fi alarm sends the push notification directly to your mobile apps. If there's GSM cellular for backup, when the Wi-Fi network is offline, it will also send you the SMS and voice call. You can respond immediately via the apps, SMS, or key operation of the phone.

### 3. What internet connection do I need for Wi-Fi system?

All contemporary Wi-Fi standards on 2.4 GHz are supported. The Internet speed has effects on the system performance. A fast and well-functioning Internet connection is recommended for optimum performance.

### 4. Do I have to pay for the app?

All available Smart Life Apps are free to download (App Store or Google Play). The complete functionality is free.

### 5. How to download the app for the security system?

Go to App Store or Google Play to download the application by entering the keyword of "Smart Life".

### 6. Is Smart Life app applied to all mobile phones?

For all smartphones with a recent version of an iOS or Android operating system, this app is available to download and use. For this functionality, depending on the system, a mobile connection or mobile Internet / Wi-Fi connection is necessary.

## 7. What's the maximum range between the control panel and accessories?

It's 100 meters in open area. The walls might shorten the distance, it's recommended to install the accessories at the right place, and move the panel to adjust a better signal receiving. If the house is too large, it's better to add a signal repeater to boost the coverage.

## 8. Will my alarm system work in the event of a power failure?

Yes. The system has rechargeable back-up batteries which can support it working for 6 hours. When the power is recovered, the battery will be recharged. Adapter wire cannot be cut to make sure enough power to the panel.

## 9. The SIM card was installed in the control panel, but it cannot connect to the GSM cellular network.

- A. The alarm system support only GSM SIM card, SIM Card for CDMA network will not work.
- B. Make sure the system is off when you insert SIM card.
- C. Watch the bottom LED light, if the LED flashes quickly, the GSM signal is unnormal, please move the control panel near the outside wall or window to improve the signal reception.
- D. SIM card must be activated, and make sure there's enough credit in the SIM card.

## 10. What will happen once power is off or internet is cut?

Once power is off or network is cut, android App will be off-line after waiting 20-30seconds, it will not reconnect, you need go back to the device list, but iOS will reconnect.

## 11. Keypad Operation Failed

When the keypad background light is totally off, please press Activate Key to turn on 50% background light then the keypad can be operated.

## PIR Motion Detector

### 1. Why PIR Motion Detector beeps without detecting intruders?

If PIR Motion Detector beeps, and LED indicator flashes continuously, the detector is in low battery. Please change the battery immediately.

### 2. Why PIR Motion detector does not detect movement?

- A. Please make sure the control panel is in arming status, not at stay (home)mode or disarming status.
- B. Please make sure the LED of PIR motion detector lights up when you walk in the detection area.
- C. Movement should cross the detection and within 8 meters range.
- D. The detector enters sleeping mode to save power after first detection. If there's no movement within 4 minutes, the detector goes back to the working state. If there's detection occurs within 4 minutes, the time detector goes back to working state will be added accordingly.
- E. Make sure the insider battery contact well or not.
- F. Check the board put well or not.
- G. If zone jumper is changed, please enroll the sensor to the system again.

### 3. If the PIR motion detector pet-immunity?

No. The PIR supplied in standard kit is normal PIR. If you have pets at home, please adjust the installing height to allow your pets to roam below the mounting height of the unit without causing alarms.

### 4. There's no one passerby the room, but the detector trigger the alarm

- A. Check if there's any pet at home, the PIR supplied in the standard kit is normal one, not pet-immune one.
- B. Please avoid mounting the P.I.R. motion detector at the place where rapid heat changes such as window, air conditioner, light, electric heater, refrigerator, oven, stove etc.
- C. Avoid strong sunlight.
- D. The installation height and range should be in the detection area.